

TetraCon 700 IQ

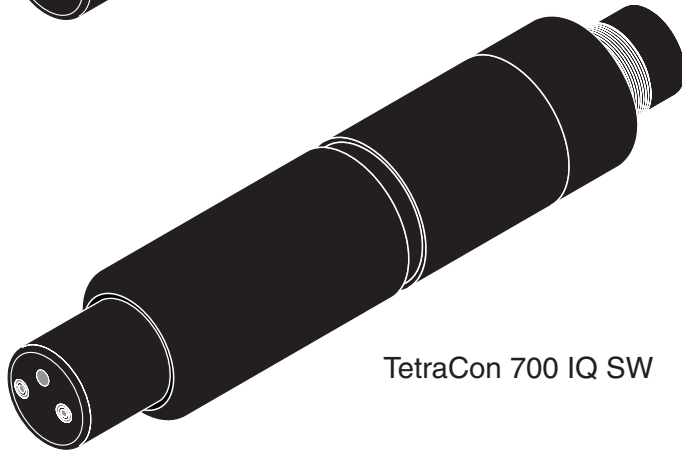

TetraCon 700 IQ SW

TetraCon[®] 700 IQ (SW)

IQ SENSOR NET - CONDUCTIVITY SENSOR



a xylem brand

Copyright

© 2021 Xylem Analytics Germany GmbH
Printed in Germany.

TetraCon® 700 IQ (SW) - Contents

1	Overview	5
1.1	How to use this component operating manual	5
1.2	Structure of the TetraCon® 700 IQ (SW)	6
1.3	Recommended fields of application	6
2	Safety	7
2.1	Safety information	7
2.1.1	Safety information in the operating manual	7
2.1.2	Safety signs on the product	7
2.1.3	Further documents providing safety information	7
2.2	Safe operation	8
2.2.1	Authorized use	8
2.2.2	Requirements for safe operation	8
2.2.3	Unauthorized use	8
3	Commissioning	9
3.1	Scope of delivery	9
3.2	Installation	9
3.3	Commissioning / Getting the sensor ready for measuring	10
3.4	Setting table for the TetraCon® 700 IQ (SW)	11
4	Measurement / operation	13
4.1	Measuring	13
4.2	Application-dependent settings	14
4.2.1	General information	14
4.2.2	Determining the cell constant in a user-specific measuring environment	14
5	Maintenance, cleaning, disposal	16
5.1	General maintenance instructions	16
5.2	Cleaning	16
5.3	Disposal	17
6	What to do if ...	18
7	Technical data	20
7.1	Measuring characteristics	20

7.2	Application characteristics	21
7.3	General data	22
7.4	Electrical data	23
7.5	Characteristic data on delivery	23
8	Indexes	24
8.1	Explanation of the messages	24
8.1.1	Error messages	24
8.2	Status info	25

1 Overview

1.1 How to use this component operating manual

Structure of the IQ SENSOR NET operating manual

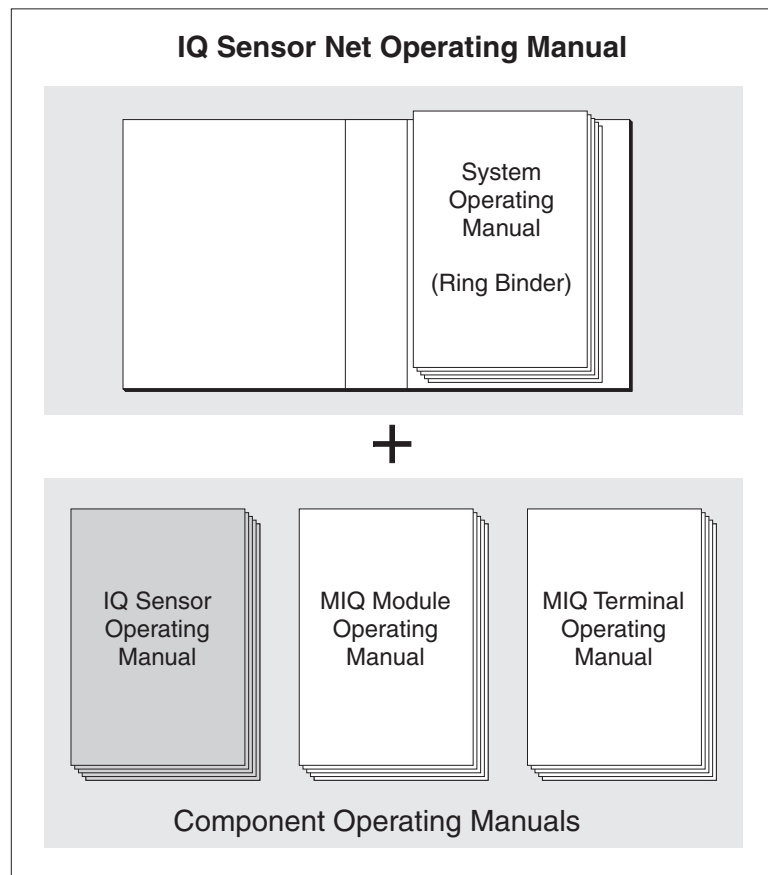

Fig. 1-1 Structure of the IQ SENSOR NET operating manual

The IQ SENSOR NET operating manual has a modular structure like the IQ SENSOR NET system itself. It consists of a system operating manual and the operating manuals of all the components used.

Please file this component operating manual into the ring binder of the system operating manual.

1.2 Structure of the TetraCon® 700 IQ (SW)

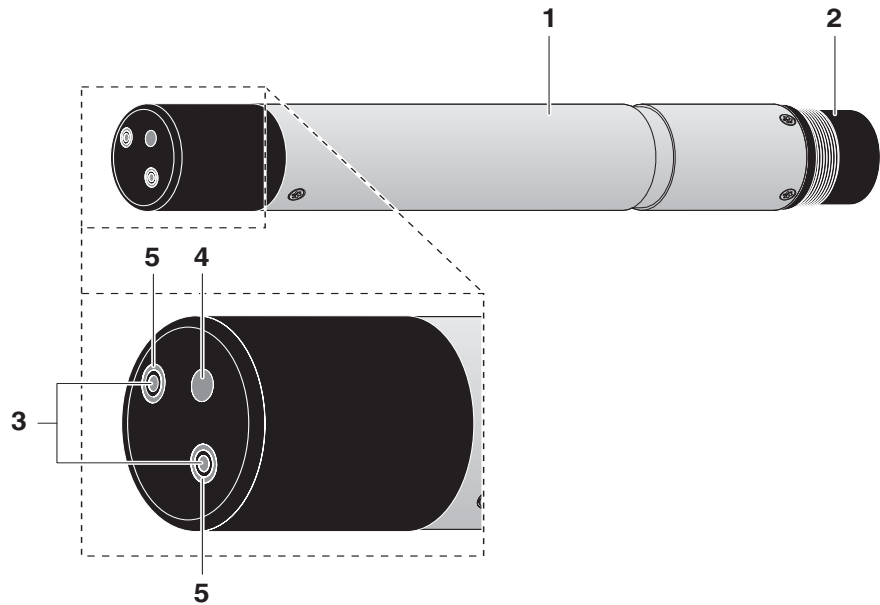

Fig. 1-2 Structure of the conductivity sensor (Example: TetraCon® 700 IQ)

1	Shaft
2	Connection head
3	Voltage electrodes
4	Temperature sensor
5	Current electrodes (ring)

Characteristics

The principle of the measurement method makes it possible to avoid influences from primary or secondary polarization effects. This ensures a high degree of measuring accuracy.

A modern epoxy sealing technique reduces the chances of breakage of the sensor in the rough industrial environment.

1.3 Recommended fields of application

TetraCon® 700 IQ (SW)

Stationary measurements in water/wastewater applications.

TetraCon 700 IQ SW

Stationary measurements in seawater and brackish water, aquaculture.

2 Safety

2.1 Safety information

2.1.1 Safety information in the operating manual

This operating manual provides important information on the safe operation of the product. Read this operating manual thoroughly and make yourself familiar with the product before putting it into operation or working with it. The operating manual must be kept in the vicinity of the product so you can always find the information you need.

Important safety instructions are highlighted in this operating manual. They are indicated by the warning symbol (triangle) in the left column. The signal word (e.g. "CAUTION") indicates the level of danger:



WARNING

indicates a possibly dangerous situation that can lead to serious (irreversible) injury or death if the safety instruction is not followed.



CAUTION

indicates a possibly dangerous situation that can lead to slight (reversible) injury if the safety instruction is not followed.

NOTE

indicates a situation where goods might be damaged if the actions mentioned are not taken.

2.1.2 Safety signs on the product

Note all labels, information signs and safety symbols on the product. A warning symbol (triangle) without text refers to safety information in this operating manual.

2.1.3 Further documents providing safety information

The following documents provide additional information, which you should observe for your safety when working with the measuring system:

- Operating manuals of other components of the measuring system (Power supply units, controllers, accessories)
- Safety datasheets of calibration and maintenance equipment (e.g. cleaning solutions).

2.2 Safe operation

2.2.1 Authorized use

The authorized use of the TetraCon® 700 IQ (SW) consists of its use as a sensor in the IQ SENSOR NET. Only the operation and running of the sensor according to the instructions and technical specifications given in this operating manual is authorized (see chapter 7 TECHNICAL DATA). Any other use is considered unauthorized.

2.2.2 Requirements for safe operation

Note the following points for safe operation:

- The product may only be operated according to the authorized use specified above.
- The product may only be supplied with power by the energy sources mentioned in this operating manual.
- The product may only be operated under the environmental conditions mentioned in this operating manual.
- The product may not be opened.

2.2.3 Unauthorized use

The product must not be put into operation if:

- it is visibly damaged (e.g. after being transported)
- it was stored under adverse conditions for a lengthy period of time (storing conditions, see chapter 7 TECHNICAL DATA).

3 Commissioning

3.1 Scope of delivery

- TetraCon® 700 IQ (SW)
- The sensor is fitted with protective caps
- Operating manual.

3.2 Installation

Connection cable

A sensor connection cable of the SACIQ or SACIQ SW type is required to connect the sensor. The cable is available in different lengths. Compared to the standard model SACIQ, the SACIQ SW sensor connection cable is optimized regarding its corrosion resistance in seawater and brackish water and adapted for use in conjunction with the TetraCon® 700 IQ SW. Information on this and other IQ SENSOR NET accessories is given in the WTW catalog and on the Internet.



How to connect the sensor connection cable to the terminal strip of an MIQ module is described in chapter 3 Installation of the IQ SENSOR NET system operating manual.

Are the plug connections dry?

Before connecting the sensor and sensor connection cable, please make sure that the plug connections are dry. If moisture gets into the plug connections, first dry the plug connections (dab them dry or blow them dry using compressed air).



Do not suspend the sensor on the sensor connection cable. Use a sensor holder or armature. Information on this and other IQ SENSOR NET accessories is given in the WTW catalog and on the Internet.

Connecting the sensor to the sensor connection cable

- 1 Take the protective caps off the plug connections of the sensor and the SACIQ (SW) sensor connection cable and keep them safe.
- 2 Plug the socket of the SACIQ (SW) sensor connection cable onto the plug head connector of the sensor. At the same time, rotate the socket so that the pin in the plug head connector (1) clicks into one of the two holes in the jack.
- 3 Then, screw the coupling ring (2) of the sensor connection cable onto the sensor up to the stop.

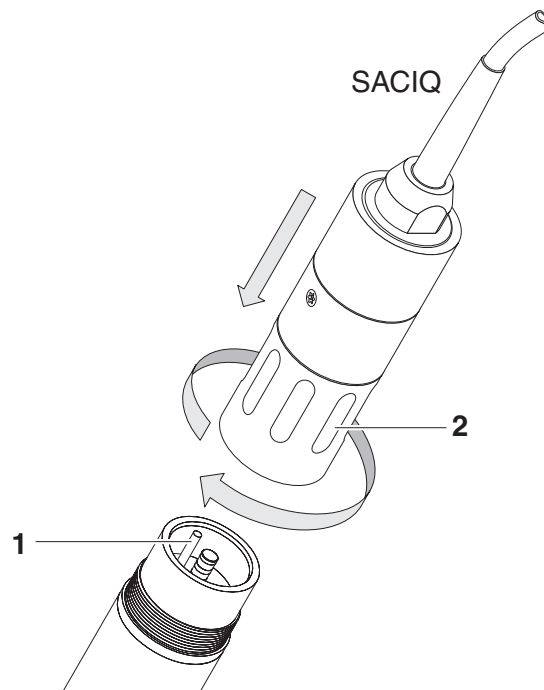

Fig. 3-1 Connecting the sensor

3.3 Commissioning / Getting the sensor ready for measuring

- 1 Pull the protective cap off the sensor.
- 2 If required, assign a user-defined name to the sensor (see relevant IQ SENSOR NET system operating manual).
- 3 Set up the sensor (see section 3.4).

3.4 Setting table for the TetraCon® 700 IQ (SW)

Carrying out settings

Using <S>, switch from the measured value display to the main menu of the settings. Then navigate to the setting menu (setting table) of the sensor. The exact procedure is given in the relevant IQ SENSOR NET system operating manual.

Menu item	Selection/values	Explanations
<i>Measuring mode</i>	<ul style="list-style-type: none"> ● <i>Conductivity</i> ● <i>Salinity</i> ● <i>TDS</i> ● <i>Conductivity /cm</i> 	Measured parameter in the measured value display (<i>TDS</i> = total dissolved solids; Information on the determination of TDS: see www.xylyanalytics.com)
<i>Measuring ranges with Measuring mode Conductivity / cm</i>	<ul style="list-style-type: none"> ● <i>AutoRange</i> ● <i>0 ... 20.00 µS/cm</i> ● <i>0 ... 200.0 µS/cm</i> ● <i>0 ... 2000 µS/cm</i> ● <i>0 ... 20.00 mS/cm</i> ● <i>0 ... 200.0 mS/cm</i> ● <i>0 ... 500.0 mS/cm</i> 	These measuring ranges are available for selection. If the <i>AutoRange</i> menu item is selected, the measurement range selection and switchover is made automatically.
<i>Measuring ranges with Measuring mode Conductivity / m</i>	<ul style="list-style-type: none"> ● <i>AutoRange</i> ● <i>0 ... 2.000 mS/m</i> ● <i>0 ... 20.00 mS/m</i> ● <i>0 ... 200.0 mS/m</i> ● <i>0 ... 2000 mS/m</i> ● <i>0 ... 20.00 S/m</i> ● <i>0 ... 50.00 S/m</i> 	
<i>Measuring range in Measuring mode Salinity</i>	<i>0 .. 70</i>	The measuring range is permanently set.
<i>Measuring range in Measuring mode TDS</i>	<ul style="list-style-type: none"> ● <i>0 ... 2000 mg/l</i> ● <i>0.0 ... 200.0 g/l</i> 	These measuring ranges are available for selection.
<i>Temperature mode</i>	<ul style="list-style-type: none"> ● °C ● °F 	Unit of the measured temperature value (Celsius, Fahrenheit).

Menu item	Selection/values	Explanations
<i>Temp. compensation with Measuring mode Conductivity and TDS</i>	<ul style="list-style-type: none"> ● <i>none</i> ● <i>nonlinear</i> ● <i>linear with setting</i> 	<ul style="list-style-type: none"> ● For natural waters (groundwater, surface water, drinking water), salinity (seawater) according to IOT ● Other aqueous measuring mediums
<i>Temp. compensation linear with Measuring mode Conductivity and TDS</i>	0.5 ... 3.0 %/K	Factor for linear temperature compensation. This menu item only appears if linear temperature compensation is selected.
<i>Reference temp. with Measuring mode Conductivity and TDS</i>	<ul style="list-style-type: none"> ● <i>Tref20</i> (20 °C) ● <i>Tref25</i> (25 °C) 	The reference temperature is the basis for calculating the temperature compensation.
<i>TDS factor with Measuring mode TDS</i>	0.40 .. 1.00	Factor for automatic calculation of the total dissolved solids by the sensor.
<i>Cell constant</i>	0.826 ... 1.008 cm ⁻¹	Here you can set the cell constant if this is necessary for a special application, e.g. when using a flow-thru vessel.
<i>Temp. adjustment</i>	-1.5 ... +1.5 K	Here you can balance the temperature sensor in the sensor against a reference temperature measurement.
<i>Save and quit</i>		The settings are stored. The display switches to the next higher level.
<i>Quit</i>		The settings are not stored. The display switches to the next higher level.

4 Measurement / operation

4.1 Measuring



CAUTION

Contact with the sample can lead to danger to the user! Depending on the type of sample, suitable protective measures must be taken (protective clothing, protective goggles, etc.).



Please make sure that, during measurement, the electrodes of the sensor are surrounded by a gap of at least 5 cm at the base and sides (boundary fields). If the gap is less than that, the cell constant changes. This leads to incorrect measurement results. If the gap cannot be maintained, e.g. in narrow pipes, the cell constant can be adjusted to suit the installation conditions (see section 4.2.2).

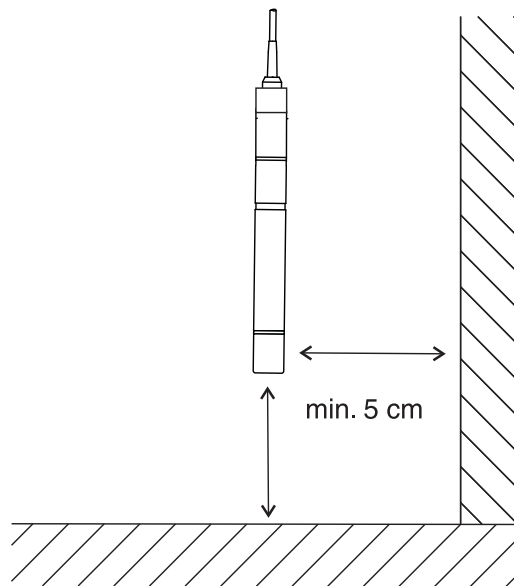

Fig. 4-1 Distance of the sensor from the edge

- 1 Immerse the sensor in the measuring medium.
- 2 The measured value is immediately available.

4.2 Application-dependent settings

4.2.1 General information

The TetraCon® 700 IQ (SW) conductivity sensor is stable over the long term. When being used for the authorized use of the sensor in water/wastewater applications, it is immediately ready for use.



Normally, the conductivity measuring cell does not age. Special measuring media (e.g. strong acids and bases, organic solvents) or temperatures that are too high may considerably reduce its lifetime or lead to damage. No warranty claims can be made for mechanical damage or any failure caused by these types of measuring media.

Adapting the cell constant to the installation location

In the case of special installation conditions, it may be necessary to adapt the cell constant (due to the influence of the measuring environment, e.g. of boundary fields).



The cell constant is stored in the controller. It is automatically allocated to the substitute sensor when the sensor is exchanged.

Cell constants with WTW installation accessories

For some products of the WTW accessory program that require a correction of the cell constant, you will find the correct values to set in the chapter 7 TECHNICAL DATA of this operating manual (if it is possible to specify the values). If necessary, special installation recommendations for the TetraCon® 700 IQ (SW) can be found in the accessory operating manual. In case of doubt it is necessary to determine the cell constant according to section 4.2.2.



The setting of the cell constant is made in the setting menu of the sensor according to section 3.4.

4.2.2 Determining the cell constant in a user-specific measuring environment

- 1 Immerse the operable conductivity sensor in the test sample in the measuring environment and wait until the measured value is stable.
- 2 Read the conductivity on the display and note it down (-> χ_D).

- 3 Take a representative sample simultaneously with the conductivity measurement and from the immediate vicinity of the sensor if possible.
- 4 Determine the conductivity of the sample **without the influence of boundary fields** (-> χ_X). The measurement can, for example, be performed as follows:
 - Measuring in the laboratory using a laboratory conductivity measuring cell
 - Measuring using the TetraCon® 700 IQ (SW) while observing the bottom and lateral gaps according to section 4.1 MEASURING.

Attention: Set the same procedure for the temperature compensation as for measuring the χ_D !

- 5 Read and note down the currently set cell constant in the setting menu of the sensor (see section 3.4) (-> K_A).
- 6 Calculate the new cell constant K_N according to:

$$K_N = (\chi_X / \chi_D) \cdot K_A$$

- 7 Set and store the new cell constant K_N (see section 3.4).

5 Maintenance, cleaning, disposal

5.1 General maintenance instructions



CAUTION

Contact with the sample can lead to danger to the user! Depending on the type of sample, suitable protective measures must be taken (protective clothing, protective goggles, etc.).

Maintenance condition

We recommend to switch on the maintenance condition each time before removing the sensor from its measuring position. This avoids any unintended reactions of the linked outputs. For detailed information on the maintenance condition please refer to the relevant IQ SENSOR NET system operating manual.

Maintenance-free operation

The TetraCon® 700 IQ (SW) conductivity sensor operates without the need for any maintenance.

5.2 Cleaning

If the sensor is heavily contaminated, this can affect the measuring accuracy. Therefore, we recommend to clean the sensor regularly after to visual checks. Thorough cleaning of the sensor is particularly recommended before measuring lower values of conductivity, as well as before adjusting the measured value.



We do not recommend to unscrew the sensor from the sensor connection cable in order to clean it. Otherwise, moisture and/or dirt can get into the plug connection where they can cause contact problems.

If you would like to disconnect the sensor from the sensor connection cable, please note the following points:

- Before disconnecting the sensor from the SACIQ (SW) sensor connection cable, remove any larger pieces of contamination from the sensor, particularly in the area of the plug connection (brush it off in a bucket of tapwater, wash it off with a hose or wipe it off with a cloth).
- Unscrew the sensor from the SACIQ (SW) sensor connection cable.
- Always place a protective cap on the plug head of the sensor and on the SACIQ (SW) sensor connection cable so that no moisture or dirt can get into the contacting surfaces.
- In a corrosive environment, close the socket of the sensor connection cable (while it is dry) with the screw-on dust cover SACIQ-Plug to protect the electrical contacts against corrosion. The protective cap is available as an accessory under the order number 480 065. It is included in the standard scope of delivery of the SACIQ SW sensor connection cable.

Cleaning	Contamination	Cleaning agents	Reaction time at room temperature
	Water-soluble substances	Tap water	Any
	Fats and oils	Warm water and household detergent;	Any
		In the case of heavy contamination: Methylated spirits	Maximum of 5 minutes
	Lime and hydroxide deposits	Acetic acid (10 %)	max. 5 minutes

5.3 Disposal

We recommend to dispose of the sensor as electronic refuse.

6 What to do if ...

No temperature display and/or no conductivity display

Cause	Remedy
System setting incorrect	Correct the system setting
Temperature sensor or conductivity sensor defective	Return the conductivity sensor

Measurement does not function

Cause	Remedy
Protective cap still on conductivity sensor	Pull off the protective cap
System setting incorrect	Correct the system setting

Measurement provides implausible measured values

Cause	Remedy
Conductivity sensor heavily contaminated	Clean the conductivity sensor
Boundary field not maintained	During measurement, the electrodes of the conductivity sensor must be surrounded by a gap of at least 5 cm at the base and sides. Otherwise, the cell constant can change (see section 4.2.2)
Electrodes damaged	Return the sensor
System setting incorrect	Correct the system setting
Measuring range exceeded	Make sure the correct sensor is being used for the application
The sensor was installed in an armature and the boundary field is not sufficient	<ul style="list-style-type: none"> – Set the cell constant to the value of the installed state (if known) – If the cell constant of the sensor in the installed state is not known, set the measured value to the nominal value of a sample (see section 4.2 APPLICATION-DEPENDENT SETTINGS)

Measured value flashing	Cause	Remedy
	Maintenance condition is active	<ul style="list-style-type: none"><li data-bbox="1038 392 1461 667">– If the maintenance condition was activated manually (e.g. by pressing the <C> key): Switch off the maintenance condition manually in the menu <i>Display/Options</i> (see IQ SENSOR NET system operating manual)<li data-bbox="1038 678 1461 882">– If the maintenance condition was activated automatically (e.g. by the cleaning system): The maintenance condition will be deactivated automatically

7 Technical data

7.1 Measuring characteristics

Measuring principle

Conductivity sensor with 4-electrode measuring cell;
Integrated microprocessor electronics, shielded 2-wire connection for power and data transmission.

Measuring ranges and resolution

Measuring mode	Measuring range	Resolution
Conductivity in S/cm	10.00 µS/cm ... 500.0 mS/cm	
	Display ranges (manual or automatic with <i>AutoRange</i>):	
	0.00 ... 20.00 µS/cm	0.01 µS/cm
	0.0 ... 200.0 µS/cm	0.1 µS/cm
	0 ... 2000 µS/cm	1 µS/cm
	0.00 ... 20.00 mS/cm	0.01 mS/cm
	0.0 ... 200.0 mS/cm	0.1 mS/cm
Conductivity in S/m	0.0 ... 500.0 mS/cm	0.1 mS/cm
	1.000 mS/m ... 50.00 S/m	
	Display ranges (manual or automatic with <i>AutoRange</i>):	
	0.000 ... 2.000 mS/m	0.001 mS/m
	0.00 ... 20.00 mS/m	0.01 mS/m
	0.0 ... 200.0 mS/m	0.1 mS/m
	0 ... 2000 mS/m	1 mS/m
Salinity	0.00 ... 20.00 S/m	0.01 S/m
	0.00 ... 50.00 S/m	0.01 S/m
TDS	0.0 ... 70.0	0.1
TDS	0 ... 2000 mg/l	1 mg/L
	0.0 ... 200.0 g/l	0.1 g/l

Measurement accuracy (Conductivity)

± 2 % of measured value ± 1 Digit
(in standard solution, 25 °C,
with nonlinear temperature compensation [according DIN 38404])

Adjustable temperature compensation	Compensation	Temperature range
	Linear	0 °C ... + 60 °C (32 ... 140 °F)
	Nonlinear	+ 5 °C ... + 35 °C (41 ... 95 °F) according to DIN 38404 + 35 °C ... + 60 °C (95 ... 140 °F) according to WTW procedure
	None	
Temperature measurement	Temperature sensor	integrated NTC
	Measuring range	- 5 °C ... + 60 °C (23 ... 140 °F)
	Accuracy	± 0.5 K
	Resolution	0.1 K
	Response time t_{90}	< 60 s
	Response time t_{95}	< 120 s

7.2 Application characteristics

Allowed temperature range	Measuring medium	- 5 °C ... + 60 °C (23 ... 140 °F)
	Storage/transport	- 5 °C ... + 65 °C (23 ... 149 °F)
Allowed pH range of the test sample	4 ... 12	
Pressure resistance	Sensor with connected SACIQ (SW) sensor connection cable:	
	Max. allowed overpressure	10 ⁶ Pa (10 bar)
	The sensor meets all requirements according to article 3(3) of 97/23/EG ("pressure equipment directive").	
Type of protection	Sensor with connected SACIQ (SW) sensor connection cable: IP 68, 10 bar (10 ⁶ Pa)	
Depth of immersion	min. 10 cm; max. 100 m depth	
Operating position	Any	

Approach flow No minimum approach flow required

Fields of application	TetraCon® 700 IQ (SW)	Stationary measurements in wa- ter/wastewater applications
	TetraCon 700 IQ SW	Stationary measurements in seawater and brackish water, aquaculture

7.3 General data

Dimensions (mm)

TetraCon 700 IQ:

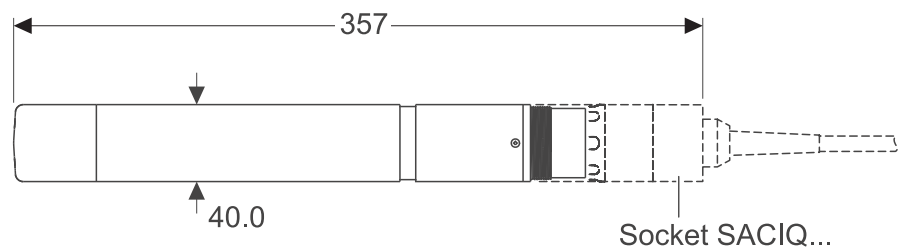

TetraCon 700 IQ SW:

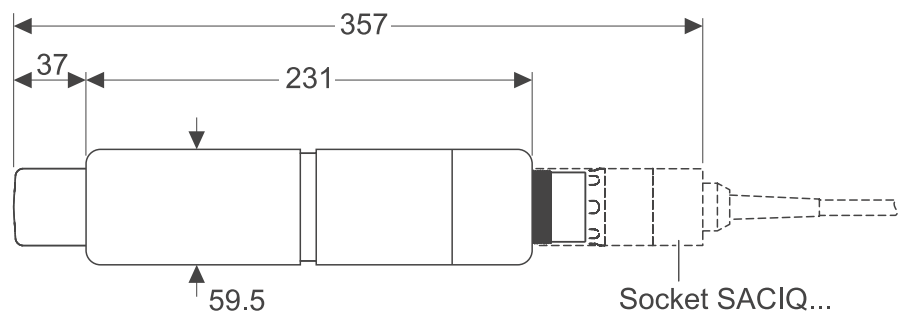

Weight (without sensor connection cable)	TetraCon 700 IQ	approx. 660 g
	TetraCon 700 IQ SW	approx. 1170 g

Connection technique Connection via the SACIQ or SACIQ SW sensor connection cable

Material	Shaft:	
	– TetraCon 700 IQ	V4A stainless steel 1.4571
	– TetraCon 700 IQ SW	POM
	Sensor head	PVC, epoxy (filler)

Electrodes, housing of the temperature sensor	Graphite
Plug head connector housing	POM
Plug, 3-pole	ETFE (blue) Tefzel®

* Stainless steel can be corrodible if there are chloride concentrations of 500 mg/L or more. For applications in such media we recommend to use the SW sensors.

Instrument safety

Applicable norms	<ul style="list-style-type: none"> – EN 61010-1 – UL 3111-1 – CAN/CSA C22.2 No. 1010.1
------------------	---

7.4 Electrical data

Nominal voltage	max. 24 VDC, via the IQ SENSOR NET (Details see IQ SENSOR NET system operating manual, chapter TECHNICAL DATA)
Power consumption	0.2 W
Protective class	III

7.5 Characteristic data on delivery**Cell constant**

In free solution, i.e. base and side clearance > 5 cm	$K = 0.917 \text{ cm}^{-1} \pm 1.5 \%$
In a flow-thru system, e.g. EBST 700-DU/N	$K = 0.933 \text{ cm}^{-1} \pm 1.5 \%$

8 Indexes

8.1 Explanation of the messages

This chapter contains a list of all the message codes and related message texts for the TetraCon® 700 IQ (SW) sensor.



Information on

- the contents and structure of the log book and
- the structure of the message code

See IQ SENSOR NET system operating manual, chapter LOG BOOK.

All message codes of the TetraCon® 700 IQ (SW) end with the number "321".

8.1.1 Error messages

Message code	Message text
EA1321	<i>Meas. range exceeded or undercut</i> * <i>Check process</i> * <i>Select other meas. range</i>
EA2321	<i>Sensor temperature too high!</i> * <i>Check process and application</i>
EA3321	<i>Sensor temperature too low!</i> * <i>Check process and application</i>
ES1321	<i>Component hardware defective</i> * <i>Contact service</i>
EI3321	<i>Operational voltage too low</i> * <i>Check installation and cable lengths, Follow installation instructions</i> * <i>Power supply module overloaded</i> * <i>Check terminal and module connections</i> * <i>Defective component, replace components</i>
EI4321	<i>Operational voltage too low, no operation possible</i> * <i>Check installation and cable lengths, Follow installation instructions</i> * <i>Power supply module overloaded</i> * <i>Check terminal and module connections</i> * <i>Defective component, replace components</i>

8.2 Status info

The status info is a coded piece of information on the current status of a sensor. Each sensor sends this status info to the controller of the IQ SENSOR NET. The status info of sensors consists of 32 bits, each of which can have the value 0 or 1.

**Status info,
general structure**

0	1	2	3	4	5	6	7	8	9	10	11	12	13	14	15		
1 0 0 0 0 0 0 0								0 0 0 0 0 0 0 0								(general)	
0 0 0 0 0 0 0 0								0 0 0 0 0 0 0 0								(internal)	
16	17	18	19	20	21	22	23	24	25	26	27	28	29	30	31		

The bits 0 - 15 are reserved for general information.
The bits 16 - 21 are reserved for internal service information.

You obtain the status info:

- via a manual query in the *Einstellungen/Settings/Service/List of all components* menu (see system operating manual)
- by an automated query
 - from a superordinate process control (e. g. when connected to the Profibus)
 - from the IQ Data Server (see IQ SENSOR NET Software Pack operating manual)



The evaluation of the status info, e.g. in the case of an automated query, has to be made individually for each bit.

**Status info
TetraCon® 700 IQ (SW)**

Status bit	Explanation
Bit 0	<i>Component hardware defective</i>
Bit 1-31	-

Xylem |'zīləm|

- 1) The tissue in plants that brings water upward from the roots;
- 2) a leading global water technology company.

We're a global team unified in a common purpose: creating advanced technology solutions to the world's water challenges. Developing new technologies that will improve the way water is used, conserved, and re-used in the future is central to our work. Our products and services move, treat, analyze, monitor and return water to the environment, in public utility, industrial, residential and commercial building services settings. Xylem also provides a leading portfolio of smart metering, network technologies and advanced analytics solutions for water, electric and gas utilities. In more than 150 countries, we have strong, long-standing relationships with customers who know us for our powerful combination of leading product brands and applications expertise with a strong focus on developing comprehensive, sustainable solutions.

For more information on how Xylem can help you, go to www.xylem.com.



Service and Returns:

Xylem Analytics Germany
Sales GmbH & Co. KG
WTW
Am Achalaich 11
82362 Weilheim
Germany

Tel.: +49 881 183-325
Fax: +49 881 183-414
E-Mail wtw.rma@xylem.com
Internet: www.xylemanalytics.com



Xylem Analytics Germany GmbH
Am Achalaich 11
82362 Weilheim
Germany

